

MIXING CHAMBERS

Series
SKRA



■ **Applications**

The mixing chambers is designed for mixing (recirculation) of extract and intake air in a required ratio.

■ **Design**

The housing made of galvanized steel. The dampers with aluminium blades driven by plastic gear-wheels.

Extract and supply air dampers are interconnected with one shaft and are opened synchronously with a single actuator. The recirculation damper is opened by a separate actuator.

SKRA is equipped with two 24 V actuators for air flow control. Both actuators are driven by 0-10 V input voltage from 100% recirculation to 100% fresh air.

■ **Mounting**

Standard connection flange for rectangular air ducts or other ventilation system components.

Fixation with galvanized bolts and clamps. The mixing units are suitable both for indoor and outdoor installation in any operating position. Service access to the actuators must be provided.

Overall dimensions:

Type	Dimensions [mm]								Weight [kg]
	B	B1	B2	B3	H	H1	H2	L	
SKRA 400x200/24	400	420	940	960	200	220	240	390	20
SKRA 500x250/24	500	520	1140	1160	250	270	290	440	25
SKRA 500x300/24	500	520	1140	1160	300	320	340	490	33
SKRA 600x300/24	600	620	1340	1360	300	320	340	490	36
SKRA 600x350/24	600	620	1340	1360	350	370	390	540	40
SKRA 700x400/24	700	720	1540	1560	400	420	440	590	45
SKRA 800x500/24	800	820	1740	1760	500	520	540	690	55
SKRA 900x500/24	900	920	1940	1960	500	520	540	740	60
SKRA 1000x500/24	1000	1020	2140	2160	500	520	540	740	65

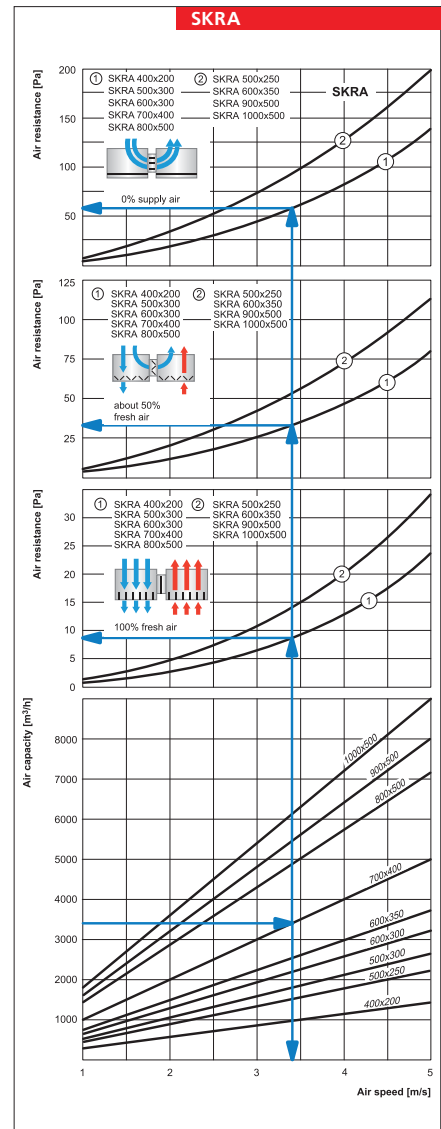
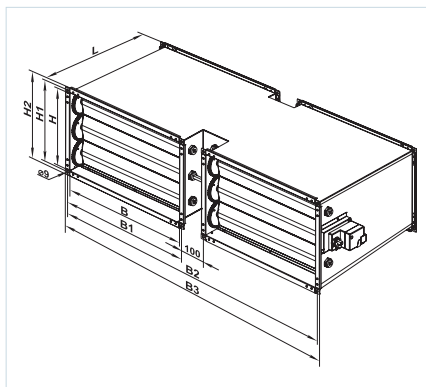

Designation key:

Series	Flange dimensions [mm]	Automatic actuator power supply voltage, V
SKRA	400x200; 500x250; 500x300; 600x300; 600x350; 700x400; 800x500; 900x500; 1000x500	24